

SPECIFICATION

1. PHYSICAL DIMENSION(UNIT: m/m):

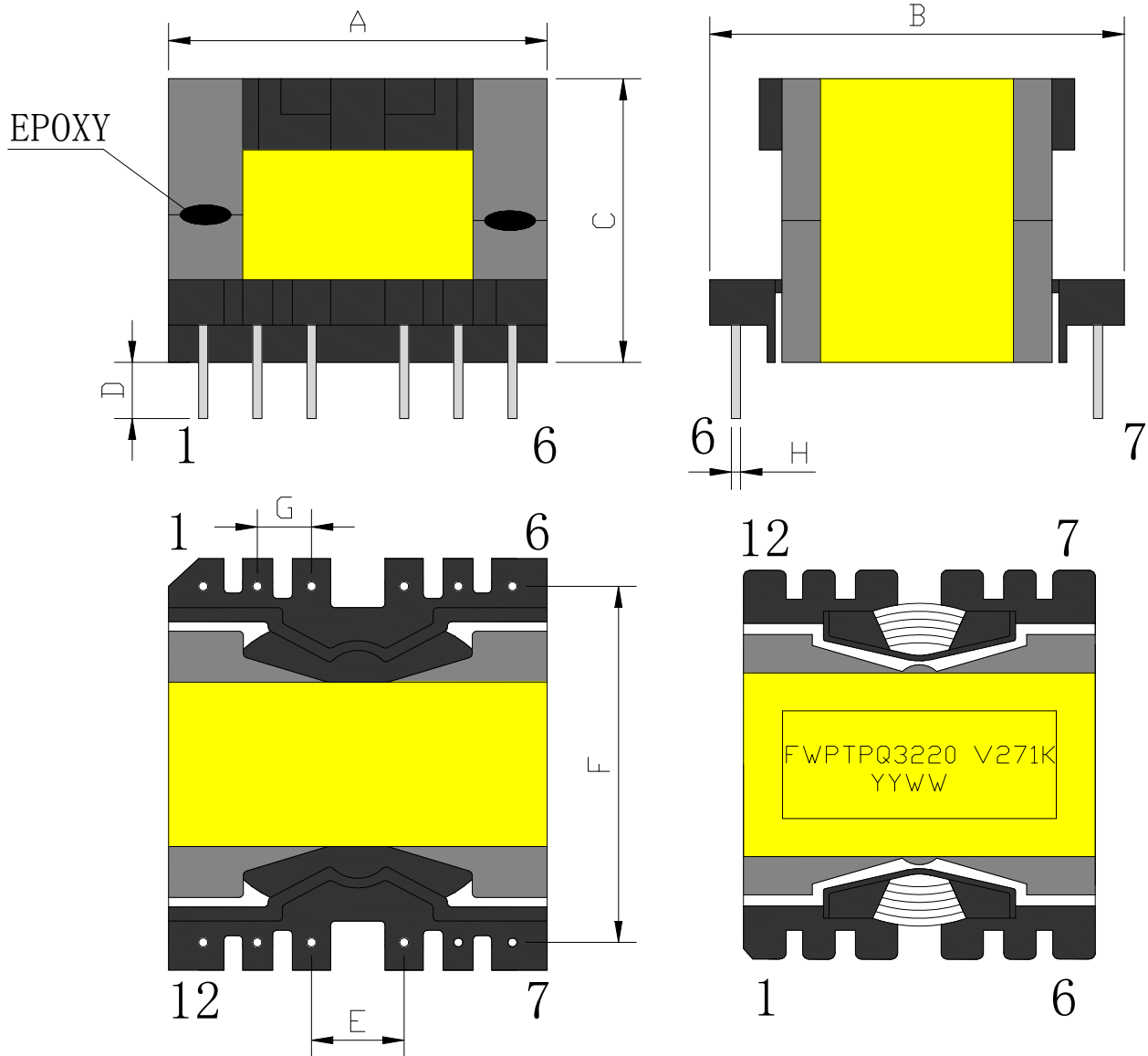

※DIMENSIONS WITHOUT TOLERANCE ARE APPROX
 ※DIMENSION DOES NOT INCLUDE SOLDER USED ONCOILS

LEAD FREE

Note: PIN7,8 cut off

DIM	A	B	C	D	E	F	G	H				
		MAX	MAX	MAX	+/-0.5	+/-0.5	+/-0.5	+/-0.5	+/-0.1			
SPEC	34.5	34.5	23.0	4.0	7.6	30.0	5.0	0.8				

	DESCRIPTION		TRANSFORMER	
	Customer P/N		PQ3220	
	FERRIWO P/N		FWPTPQ3220V271K	
SPEC. NO.	PS-1001-015	PREPARED		APPROVED

SPECIFICATION

2.WINDING TABLE:

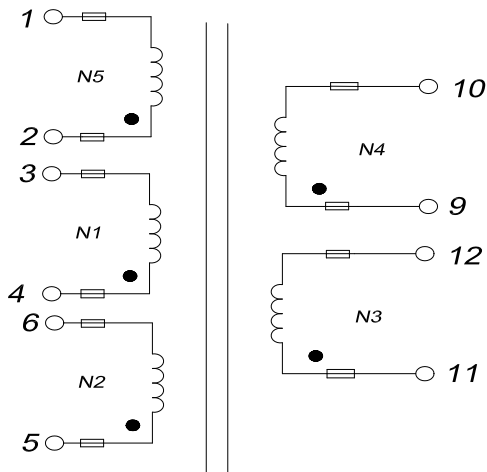

3.WINDING:

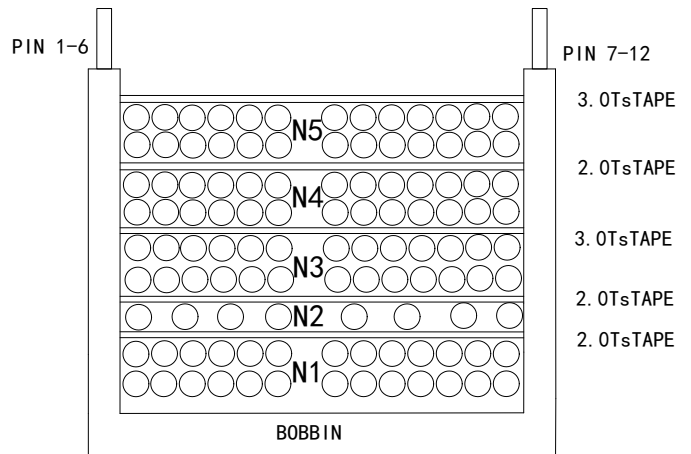

4.WINDING TABLE:

Winding NO.	Margin Tape	PIN	Wire &Wire Copper	Turns	Winding Type	Tape Layer	Tube
N1	0	4~3			Compact	2.0	F=S≈10mm
N2	0	5~6			Dispersed	2.0	F=S≈10mm
N3	0	11~12			Compact	3.0	F=S≈10mm
N4	0	9~10			Compact	2.0	F=S≈10mm
N5	0	2~1			Compact	3.0	F=S≈10mm

NOTE:

1. Products should be vacuum impregnation

*VARNISH RATIO: 1:1

*VACUUM TIME: 15~20minutes

*BAKED TEMPERATURE : 120°C±10°C , 1~1.5hours

LEAD FREE

DESCRIPTION

TRANSFORMER

Customer P/N

PQ3220

FERRIWO P/N

FWPTPQ3220V271K

SPEC. NO.

PS-1001-015

PREPARED

APPROVED

SPECIFICATION

5. ELECTRONICAL CHARACTERISTIC:

TEST CONDITION : TEMPERATURE AT 25°C
HUMIDITY AT 65 ±5% RH

TEST ITEM	TEST CONDITION	RESULT
INDUCTANCE CH-3250	@1.0KHz,0.3V (4~1) Short PIN2,3	0.27mH±10%
HI-POT TEST CH-9052	@ 5mA 1SEC (AC)	P<->S 3.75 KV; COIL<-> CORE 2.0KV;

LEAD FREE



DESCRIPTION	TRANSFORMER
Customer P/N	PQ3220
FERRIWO P/N	FWPTPQ3220V271K

SPEC. NO.	PS-1001-015	PREPARED	APPROVED
-----------	-------------	----------	----------

SPECIFICATION

6. MATERIAL LIST :

ITEM		MATERIAL	SUPPLIER OR MANUFACTURER	TEMPRATING
1	CORE	FW95 OR EQUIVALENT	HAINING FERRIWO ELECTRONICS CO., LTD.	
2	BOBBIN	PHENOLIC OR EQUIVALENT	SUMITOMO BAKELITE CO., LTD. UL NO E41429	150°C
3	WIRE	UEW	PACIFIC ELECTRIC WIRE&CABLE(SHENZHEN) CO. LTD UL NO E84081	155°C
4	TAPE	CT280	YAHUA STICKING TAPE CO.,LTD UL NO E165111	130°C
5	VARNISH	R-1038	ZHEJIANG RONGTAI TECHNICAL INDUSTRY CO.,LTD UL NO E227128	130°C
6	FLUX	TF9100	LINAN GUITONG CHEMICAL TECHNICAL CO.,LTD	
7	TIN	Sn99.3Cu0.7	HAINING ZHUCHANG METAL FOIL CO;LTD	
8	EPOXY	E-500 (BLACK)	SUZHOU EATTO ELECTRONIC MATERIAL CO.,LTD UL NO E218090	130°C
9	TUBE	TEFLON TUBE	GREAT HOLDING INDUSTRIAL CO.,LTD UL NO E156256	200°C

LEAD FREE



DESCRIPTION	TRANSFORMER
Customer P/N	PQ3220
FERRIWO P/N	FWPTPQ3220V271K

SPEC. NO.

PS-1001-015

PREPARED

APPROVED